

75

BGE series

75X75X15mm

●General Specification / 一般規格

- Motor / DC brushless motor
- Material / Frame : plastic(94V-0)
Impeller : plastic(94V-0)
- Bearing / Ball bearing;FMB
- Weight / 45g
- 馬達 / 直流單向無刷馬達
- 材質 / 框：塑膠(94V-0)
葉：塑膠(94V-0)
- 軸承 / 滾珠軸承;FMB
- 重量 / 45g



●Specification / 詳細規格 * 軸承/bearing B: 雙滾珠/ball bearing F:FMB S: 含油軸承/sleeve bearing

Model 機型	Bearing 軸承	Voltage 電壓	Operating Voltage 操作電壓	Current 電流	Speed 轉速	Max. Air Flow 最大風量	Max. Static Pressure 最大風壓	Sound 噪音	P-Q
Part No.	B / S / F	V	V	A	RPM	m ³ /min CFM	Pa In-H ₂ O	dBA	No.
BGE07015_12L	B	12	7.0~13.2	0.21	4000	0.21 7.4	60.8 0.24	43	①
BGE07015_12M	B	12	7.0~13.2	0.32	4500	0.27 9.7	135.3 0.54	47	②
BGE07015_12H	B	12	7.0~13.2	0.40	5000	0.31 10.8	167.6 0.67	49	③
BGE07015_12U	B	12	7.0~13.2	0.50	5500	0.34 11.9	202.9 0.81	51	④

● Drawing/ 圖面及出入風口

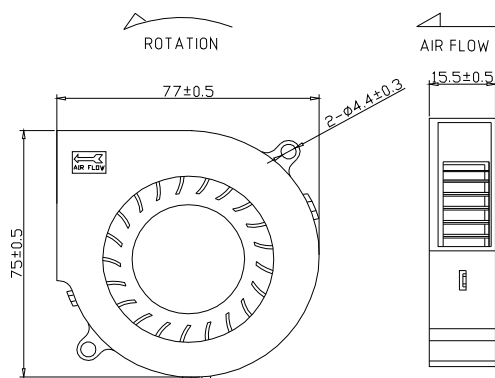

● Characteristic Curves/ 特性曲線

