

97

BGE series

97X97X33mm



●General Specification / 一般規格

- Motor / DC brushless motor
- Material / Frame : plastic(94V-0)
- Impeller : plastic(94V-0)
- Bearing / Ball bearing
- Weight / 150g
- 馬達 / 直流單向無刷馬達
- 材質 / 框：塑膠(94V-0)
- 葉：塑膠(94V-0)
- 軸承 / 滾珠軸承
- 重量 / 150克

●Specification / 詳細規格 * 軸承/bearing B: 雙滾珠/ball bearing F:FMB S: 含油軸承/sleeve bearing

Model	Bearing	Voltage	Operating Voltage	Current	Speed	Max. Air Flow		Max. Static Pressure		Sound	P-Q
機型	軸承	電壓	操作電壓	電流	轉速	最大風量		最大風壓		噪音	P-Q曲線
Part No.	B / S / F	V	V	A	RPM	m ³ /min	CFM	Pa	In-H ₂ O	dBA	No.
BGE09733_12L	B/S	12	7.0~13.2	0.21	2200	0.46	16.3	59.8	0.24	43	①
BGE09733_12M	B/S	12	7.0~13.2	0.32	2700	0.57	20.1	99.6	0.40	45	②
BGE09733_12H	B/S	12	7.0~13.2	0.60	3600	0.62	28.8	283.9	1.14	52	③
BGE09733_24L	B/S	24	14.0~26.4	0.14	2200	0.46	16.3	59.8	0.24	43	①
BGE09733_24M	B/S	24	14.0~26.4	0.18	2700	0.57	20.1	99.6	0.40	45	②
BGE09733_24H	B/S	24	14.0~26.4	0.32	3600	0.62	28.8	283.9	1.14	52	③

● Drawing/ 圖面及出入風口

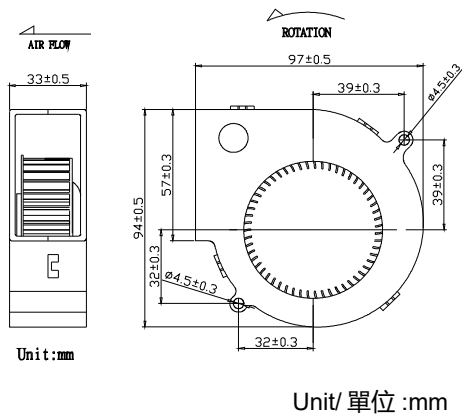

● Characteristic Curves/ 特性曲線

