

# 190 BG series

Ø190X68.5mm

## ●General Specification

- Motor / DC brushless motor
  - Material / Frame : die cast aluminum  
Impeller : plastic(94V-0)
  - Bearing / Two ball precision bearing
  - Insulator class "B"
  - Weight / 1.0kg(BGN);1.3KG(BGM)
- 馬達 / 單向無刷馬達
  - 材質 / 框：鋁合金壓鑄；  
葉：塑膠(94V-0)
  - 軸承 / 雙滾珠精密軸承
  - 絕緣等級 "B"
  - 重量 / 1.0kg(BGN);1.3KG(BGM)



## ●Specification / 詳細規格

Model	Bearing System	Rated Voltage	Rated Current	Rated Speed	Maximum Air Flow		Maximum Static Pressure		Sound Level	P-Q Curve
Part No.	B / S / F	V	A	RPM	m <sup>3</sup> /hr	CFM	Pa	In-H <sub>2</sub> O	dBA	No.
BGN19069B24U-72	B	24	3.5	3000	630	371	495	1.99	68	①
BGN19069B48U-72	B	48	1.8	3000	630	371	495	1.99	68	①
BGM19069B24U-92	B	24	3.5	3000	500	294	600	2.41	73	②
BGM19069B48U-92	B	48	1.8	3000	500	294	600	2.41	73	②

## ● Drawing / 外觀尺寸

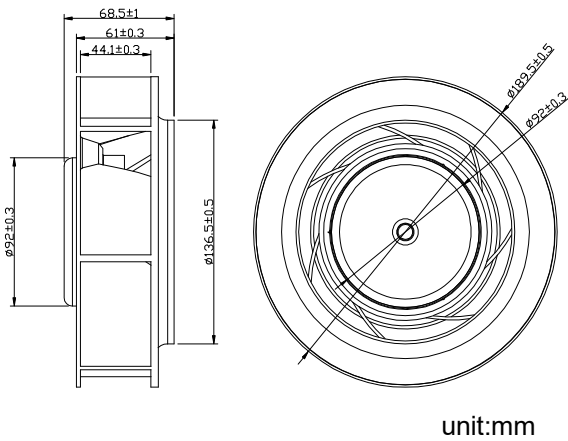

## ● Characteristic Curves / 特性曲線

